



The Easy Choice for **Variable Speed AC Gensets... with a Boost**

PMG-I

Comprehensive Solution for Energy Conversion

This **variable speed system** consists of a PMG (Permanent Magnet Generator), a single or three-phase inverter (with **AC output** and EMC filter) and a linear actuator to regulate the engine revolutions.

Adaptable to the engine models and interfacing with the control units by all the main brands, **PMG-I** represents a highly customizable solution for a compact and efficient AC generating set.

Plus the advantage of having **NSM** as your sole partner for a complete and fully integrated ready-to-use system.

PMG-I 3ph Classic and Boost

With a three-phase AC output inverter, this system is available in **20 - 30 or 40kVA** both in 50Hz and 60Hz. Very easy to be placed in parallel.

The advanced version **PMG-I 3ph Boost**, featuring an integrated battery charger, can be connected to a **supercapacitor bank** for an extended speed range and the capability of working with very high starting currents.

PMG-I 1ph

With a single-phase AC output inverter, this system is available in **3 - 6 or 10kVA** both in 50Hz and 60Hz.

The main objective of the **PMG-I** is to produce electrical energy with constant frequency and voltage, independently from the type of load ($\cos\phi$) and the engine speed.

Why Variable Speed?

The main purpose of a generating set is to provide electricity, stabilized in voltage and frequency, to all types of loads and to react to any transient.

Conventional gensets consist of an endothermic engine running at **fixed speed**, regardless of the power demanded by the load, and a synchronous alternator transforming mechanical energy into electrical energy. As a result, in the numerous applications involving variable loads, the fixed speed gensets are often oversized, as the rated output power they can supply is not always fully needed by the load.

PMG-I by NSM revolutionizes this concept thanks to **variable speed** technology.

In fact, this system adjusts the engine speed to perfectly match the power demanded by the variable load, while keeping voltage and frequency constant, independently from the type of load ($\cos\phi$) and the engine speed.

This means it only runs at the necessary rpm, allowing to save considerable amounts of energy compared to a conventional solution.

10 Reasons to Choose our Variable Speed System PMG-I:

- 1 - Performance enhancement
- 2 - High efficiency for energy savings
- 3 - High quality and stability of the output voltage
- 4 - Lower running costs
- 5 - Durability for an extended genset life
- 6 - Low emissions and low engine losses
- 7 - Noise reduction
- 8 - Lower mechanical wear for an increased MTBF
- 9 - Downsizing of the engine
- 10 - Compact and weight-optimized genset

Very compact, in comparison with a conventional fixed speed system, **PMG-I** reaches an extremely high efficiency and drastically **reduces fuel consumption**.

User friendly, turnkey, the system satisfies the growing OEM demand for gensets reduced in weight and size.

The generator is three-phase and made of permanent magnets, in order to obtain high power density in **compact volumes**.

The stability and quality of the generated voltage (THD<2%) ensure the smooth and safe functioning of electronic devices, computers, household appliances and so on.

The electronic control system guarantees stable output voltage also when load variations occur.

Engine performance is optimized at its best: the speed is electronically adjusted according to the output load so that fuel consumption and noise are drastically reduced.

Each system is **made-to-measure** to grant the desired maximum output power at a specific rpm value, in the aim of better exploiting the engine performance. In other words, the ability of PMG-I to work within a range of revolutions calls for a smaller engine, if compared with conventional fixed speed alternators.

An amazingly **high efficiency** on all range (from 88 to 90%) and consistently throughout the whole cycle (conventional fixed speed alternators maximum efficiency is reached only when working between half and full load).

Moreover, **PMG-I** is bearingless and brushless for easier maintenance.

PMG-I can be used advantageously:

- for every load requiring **low harmonic distortion** or **high voltage accuracy** (sensitive electronics, computers, TVs);
- on installations where the fuel consumption has to be drastically reduced in order to increase the time span between the refuelling intervals;
- for marine applications;
- in countryside houses;
- on campervans, recreational vehicles, service trucks;
- for mobile power generation for the film and TV industry and noise sensitive applications in general;
- for either trailer, static or vehicle-mounted and custom built gensets.



PMG-I 3ph - Classic

Permanent Magnet Generator

+ Three-phase AC Inverter

+ Actuator Kit (alternatively, engine-integrated electronic governor)

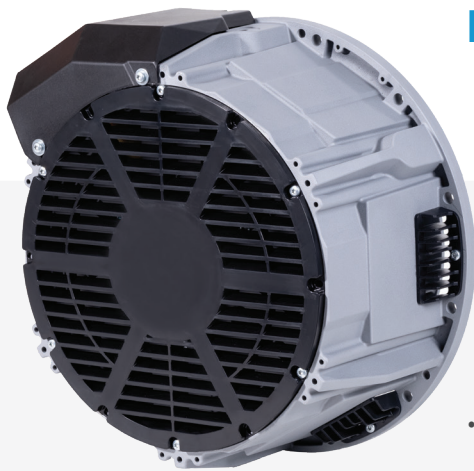

Key features:

- The PMG has a Vac 3-phase output.
- Inverter range includes: **20kVA, 30kVA** and **40kVA** three-phase AC output (400Vac 50Hz 3ph+N).
 - Available: 240Vac ÷ 480Vac, 50Hz ÷ 60Hz.
 - Electronic components developed by **NSM**.
 - Easily parallelable to obtain the total power required.
 - AC-DC **active rectifier** (The voltage drop across this rectifier is much lower, meaning a reduction in power loss and a gain in efficiency. It reduces the amount of power dissipated and allows to obtain an optimized and constant voltage).
- Complete system high efficiency.
- CAN-bus RS485 or RS232 communication line.
- *Speed range within 1000rpm.*

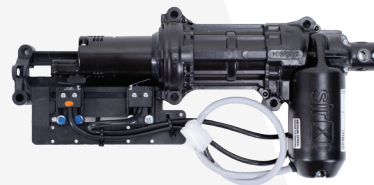

PMG-I 3ph Classic

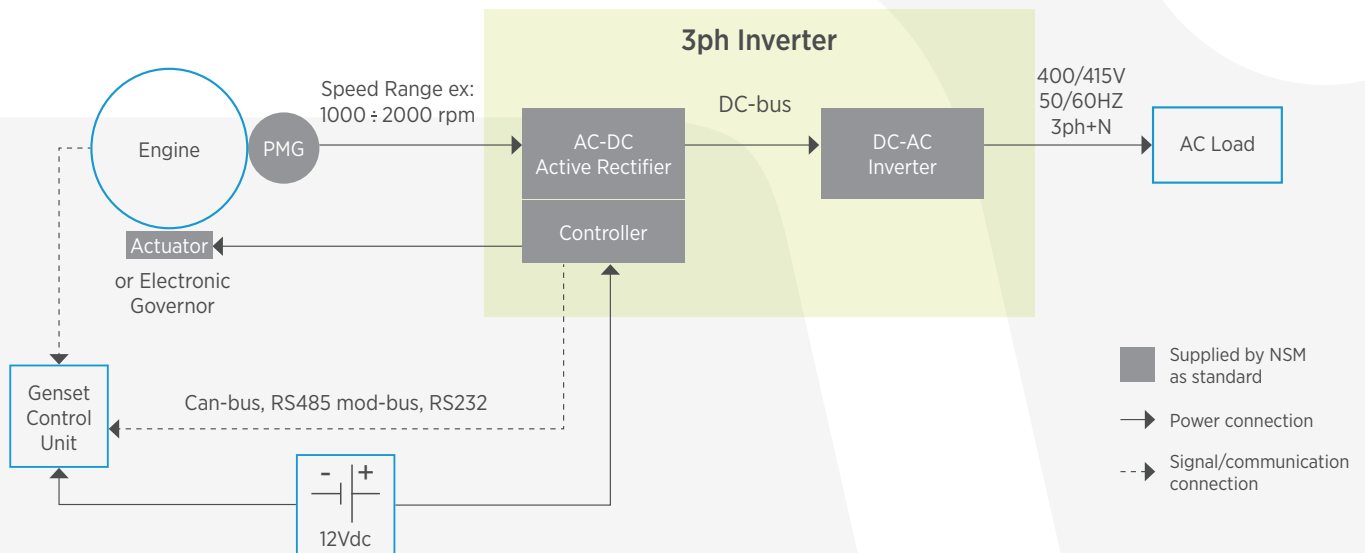

PMG-I 3ph - Boost

Permanent Magnet Generator

+ Three-phase AC Inverter **with Integrated Supercapacitor Charger**

+ Actuator Kit (alternatively, engine-integrated electronic governor)

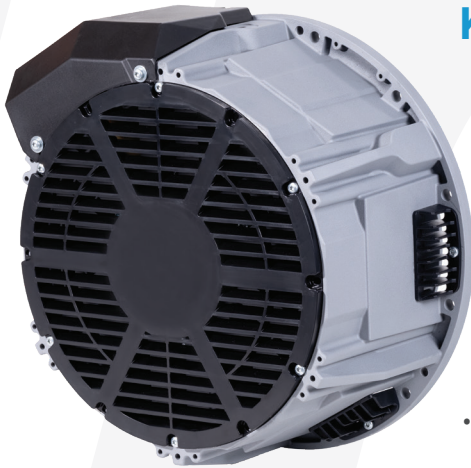

Key features:

- The PMG has a Vac 3-phase output.
- Inverter range includes: **20kVA, 30kVA** and **40kVA** three-phase AC output (400Vac 50Hz 3ph+N).
 - Available: 240Vac ÷ 480Vac, 50Hz ÷ 60Hz.
 - Electronic components developed by **NSM**.
 - Easily parallelable to obtain the total power required.
 - AC-DC **active rectifier** (The voltage drop across this rectifier is much lower, meaning a reduction in power loss and a gain in efficiency. It reduces the amount of power dissipated and allows to obtain an optimized and constant voltage).
- Complete system extraordinarily high efficiency.
- CAN-bus RS485 or RS232 communication line.

• **Instant energy reserve: PMG-I is connectable to a supercapacitor bank or pure lead batteries for immediate support energy during the engine transient state, in the aim of supplying the load until the engine runs at the needed speed.**

*Supercapacitor bank for **peak shaving**.*

- Energy buffer management.
- Extended rpm range (1:3 ratio - 1000÷3000rpm)
- **High starting current:** necessary for heavy inductive loads such as pumps and electric motors in general.
- Supercapacitor life boasts countless switching on and reloading cycles.

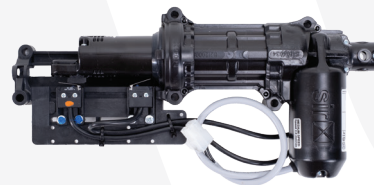

PMG-I 3ph Boost

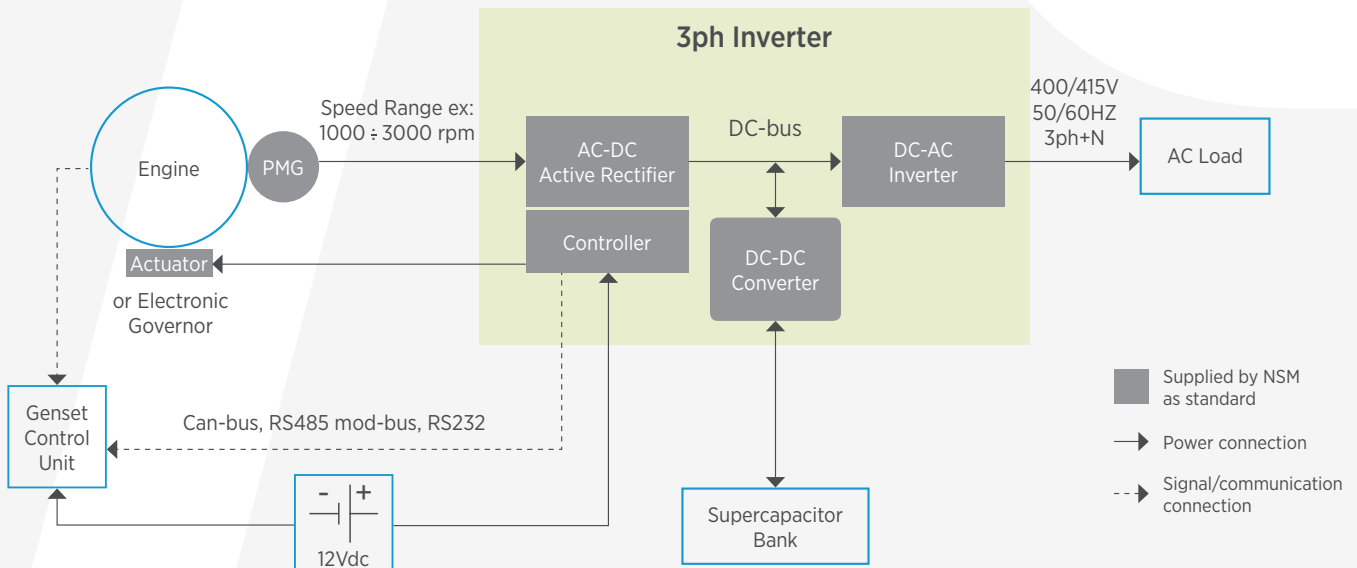

PMG-I 1ph

Permanent Magnet Generator
+ Single-phase AC Inverter
+ Actuator Kit

Key features:



- The PMG has a Vac 3-phase output
- Inverter range includes: **3kVA**, **6kVA** and **10kVA** single-phase AC output
- 50Hz and 60Hz (230V or 240V)
- Electronic components developed by NSM
- Speed range: the output voltage is directly connected to the engine speed
- High efficiency (up to 90%)
- Ultra small design
- Super compact and light but robust
- Available both in SAE or cone coupling
- Brushless and bearingless for very low maintenance

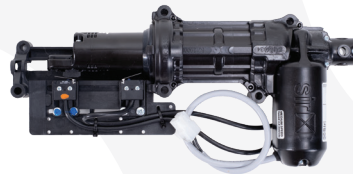

Model	Output Power 1 ph [kVA]	Efficiency (PMG + inverter) η%	Speed Range [rpm]	Weight				
				PMG cone [kg]	SAE 5* [kg]	Inverter [kg]	EMC filter [kg]	Actuator [kg]
PMG-I 1ph 150SB	3,0	0,87	2000 ÷ 3000 2400 ÷ 3600	9,0	---	5,5	1,3	2,0
PMG-I 1ph 150SC	6,0	0,87	2000 ÷ 3000 2400 ÷ 3600	10,0	---	10,0	2,0	2,0
PMG-I 1ph 180SC	10,0	0,87	2000 ÷ 3000 2400 ÷ 3600	14,5	14,0	10,0	3,0	2,0
PMG-I 1ph 185SF	10,0	0,88	1700 ÷ 2400 1900 ÷ 2700	17,5	17,0	10,0	3,0	2,0

* SAE 4 = SAE 5 + 1kg

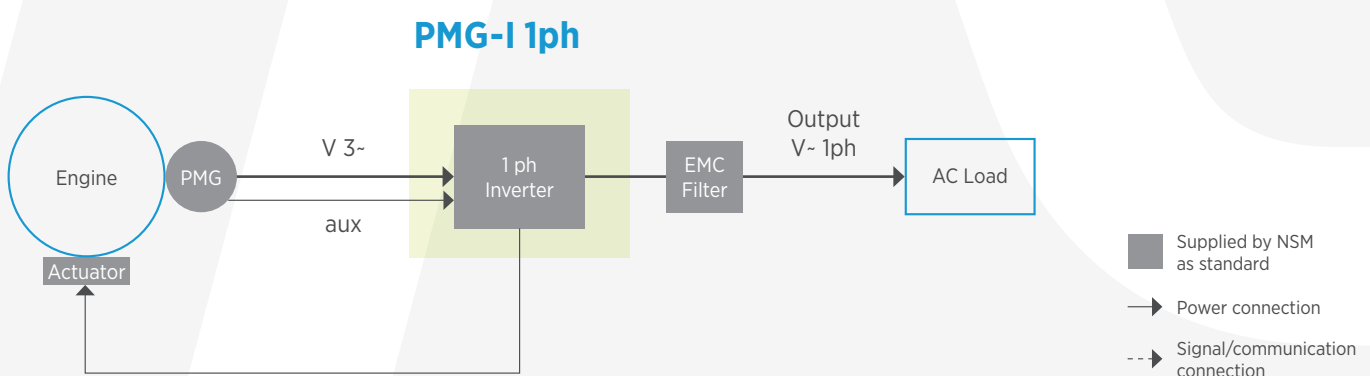

AMER Group

Amer Group is a global enterprise with 6 production facilities throughout northern Italy and Switzerland; and 3 well-integrated branches providing sales, distribution & after-sales support around the world.

This network has been growing for 40 years, thanks to our commitment, to small daily improvements and especially to the strategic choice to reinvest our profits in Research & Development and facilities.

Our comprehensive custom solutions, such as generators, electronic control systems, DC motors, traction and linear motion systems, have been developed to carefully satisfy our international partners' needs.

Thanks to them, and to a tight-knit team that shares the company vision, we have become an important key player and a worldwide point of reference.

NSM

At NSM, we are dedicated to manufacturing **synchronous alternators and welders, PTO generators, and Permanent Magnet Generators (PMG)**.

We have solid roots thanks to almost 60 years of experience in producing and exporting our high-quality machines to more than 60 countries across the world.

Consistently with our role as key industry players, we never stop researching and developing innovative solutions for whatever the future of energy generation entails.

The real value of being **Made in Italy**: a mark of origin that we can proudly bear as we are one of the very few companies boasting all the production cycles, from design to manufacturing, in our Italy-based factories.

A 100% Italian entrepreneurial story, capable of conquering international markets and anticipating industry trends.



NSM S.r.l. Via Lazio, 5/b
36015 Schio | Vicenza | Italy

T +39 0445 595888
F +39 0445 595800

info@nsmsrl.it
nsmsrl.it



amergroup.it